

Technical Rider - Dornenkönig - big setup

Stageplott

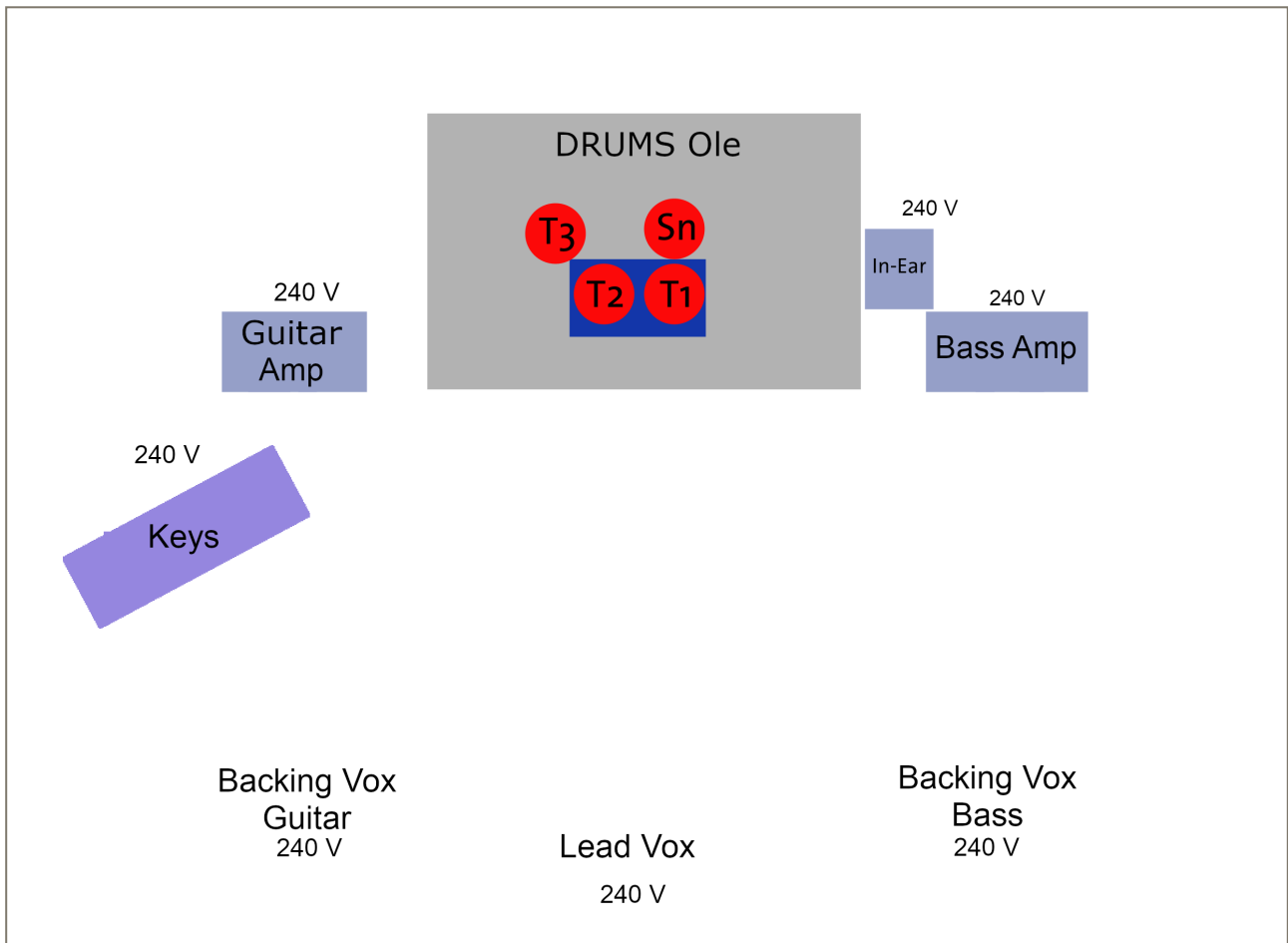

Mikrofone / Kanalbelegung:

| Ch | Instrument | |
|----|--------------|--------------------------|
| 1 | Kick | Shure Beta 91A |
| 2 | Kick | Shure Beta 52A |
| 3 | Snare top | Shure SM57 |
| 4 | Snare bottom | Shure SM57 |
| 5 | HH | Shure SM81 |
| 6 | Tom 1 | Shure Beta 56A / Beta 98 |
| 7 | Tom 2 | -“- |
| 8 | Tom 3 | -“- |
| 9 | OH 1 | Shure KSM137 o. SM81 |

| Ch | Instrument | |
|----|-----------------------|--------------------|
| 10 | OH 2 | -"- |
| 11 | Bass | D.I., XLR |
| 12 | Guitar L | Quad Cortex -> XLR |
| 13 | Guitar R | Quad Cortex -> XLR |
| 14 | Acoustic Guitar | D.I. |
| 15 | Keys L | D.I. |
| 16 | Keys R | D.I. |
| 17 | Sequencer Loops L | D.I. |
| 18 | Sequencer Loops R | D.I. |
| 19 | Sequencer Baselines L | D.I. |
| 20 | Sequencer Baselines R | D.I. |
| 21 | Sequencer Atonal L | D.I. |
| 22 | Sequencer Atonal R | D.I. |
| 23 | Sequencer Strings L | D.I. |
| 24 | Sequencer Strings R | D.I. |
| 25 | Sequencer Vocal L | D.I. |
| 26 | Sequencer Vocal R | D.I. |
| 27 | Voc Lead | Sennheiser E945 |
| 28 | Vox Drums | Shure Beta 58A |
| 29 | Vox Bass | Shure SM58 |
| 30 | Vox Guitar | Shure SM58 |
| 31 | | |
| 32 | | |
| 25 | | |

Contact:

Marc Nesselhauf
+49 151 580 25 647
marc@dornenkoenig.de